

Russian Printer-2

SERVICE MANUAL

September 29 2000
Sub ect to change

IMPORTANT SAFETY NOTICES

PREVENTION OF PHYSICAL INJURY

1. Before disassembling or assembling parts of the copier and peripherals make sure that the printer power cord is unplugged.
2. The wall outlet should be near the printer and easily accessible.
3. Note that some components of the printer and the paper tray unit are supplied with electrical voltage even if the main power switch is turned off.
4. If any adjustment or operation check has to be made with exterior covers off or open while the main switch is turned on keep hands away from electrified or mechanically driven components.
5. The inside and the metal parts of the fusing unit become extremely hot while the printer is operating. Be careful to avoid touching those components with your bare hands.

HEALTH SAFETY CONDITIONS

1. Toner and developer are non-toxic but if you get either of them in your eyes by accident it may cause temporary eye discomfort. Try to remove with eye drops or flush with water as first aid. If unsuccessful get medical attention.

OBSERVANCE OF ELECTRICAL SAFETY STANDARDS

1. The printer and its peripherals must be installed and maintained by a customer service representative who has completed the training course on those models.
2. The NVRAM on the system control board has a lithium battery which can explode if replaced incorrectly. Replace the NVRAM only with an identical one. The manufacturer recommends replacing the entire NVRAM. Do not recharge or burn this battery. Used NVRAM must be handled in accordance with local regulations.

SAFETY AND ECOLOGICAL NOTES FOR DISPOSAL

1. Do not incinerate toner bottles or used toner. Toner dust may ignite suddenly when exposed to an open flame.
2. Dispose of used toner developer and organic photoconductors in accordance with local regulations. (These are non-toxic supplies.)
3. Dispose of replaced parts in accordance with local regulations.
4. When keeping used lithium batteries in order to dispose of them later do not put more than 100 batteries per sealed box. Storing larger numbers or not sealing them apart may lead to chemical reactions and heat build-up.

LASER SAFETY

The Center for Devices and Radiological Health (CDRH) prohibits the repair of laser-based optical units in the field. The optical housing unit can only be repaired in a factory or at a location with the requisite equipment. The laser subsystem is replaceable in the field by a qualified Customer Engineer. The laser chassis is not repairable in the field. Customer engineers are therefore directed to return all chassis and laser subsystems to the factory or service depot when replacement of the optical subsystem is required.

WARNING

Use of controls, or adjustment, or performance of procedures other than those specified in this manual may result in hazardous radiation exposure.

WARNING

WARNING: Turn off the main switch before attempting any of the procedures in the Laser Unit section. Laser beams can seriously damage your eyes.

CAUTION MARKING:

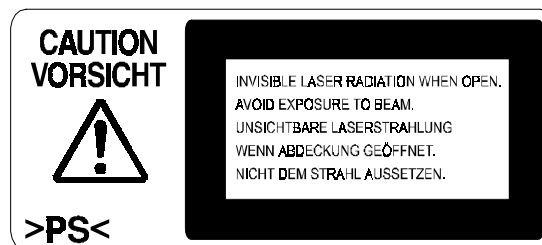
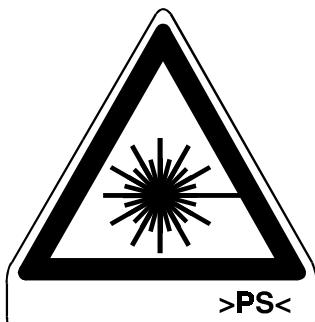

Trademarks

Microsoft Windows and MS-DOS are registered trademarks of Microsoft Corporation in the United States and /or other countries.

PostScript is a registered trademark of Adobe Systems Incorporated.

PCL is a registered trademark of Hewlett-Packard Company.

Ethernet is a registered trademark of Xerox Corporation.

PowerPC is a registered trademark of International Business Machines Corporation.

Other product names used herein are for identification purposes only and may be trademarks of their respective companies. We disclaim any and all rights involved with those marks.

TABLE OF CONTENTS

1. OVERALL MACHINE INFORMATION	1-1
1.1 SPECIFICATIONS.....	1-1
1.1.1 GENERAL SPECIFICATIONS.....	1-1
1.1.2 SUPPORTED PAPER SIZES.....	1-2
1.2 SOFTWARE ACCESSORIES.....	1-3
1.2.1 PRINTER DRIVERS.....	1-3
1.2.2 UTILITY SOFTWARE.....	1-3
1.2.3 SERVICE TOOLS.....	1-3
1.3 MACHINE CONFIGURATION.....	1-4
1.3.1 SYSTEM COMPONENTS.....	1-4
1.4 ELECTRICAL COMPONENT DESCRIPTIONS.....	1-6
1.5 BOARD STRUCTURE.....	1-8
1.5.1 OVERVIEW.....	1-8
2. DETAILED SECTION DESCRIPTIONS	2-1
2.1 DIFFERENT POINTS FROM BASE MODEL (G038).....	2-1
2.1.1 OVERVIEW.....	2-1
2.1.2 PAPER FEED SECTION.....	2-2
2.1.3 LASER EXPOSURE SECTION.....	2-2
2.1.4 DEVELOPMENT SECTION.....	2-2
2.1.5 ENGINE CONTROLLER BOARD.....	2-2
2.1.6 CONTROLLER BOARD.....	2-3
3. INSTALLATION	3-1
3.1 INSTALLING THE MACHINE.....	3-1
3.2 INSTALLING OPTIONAL UNITS.....	3-2
3.2.1 1 000-SHEET FINISHER.....	3-2
Installation Procedure.....	3-2
4. SERVICE TABLES	4-1
4.1 PRINTER CONTROLLER SERVICE MODE.....	4-1
4.2 PRINTER ENGINE SERVICE MODE.....	4-1
4.3 CONTROLLER FIRMWARE UPDATE.....	4-2
4.3.1 FIRMWARE DOWNLOAD.....	4-2
5. PREVENTIVE MAINTENANCE	5-1
6. REPLACEMENT AND ADJUSTMENT	6-1
6.1 LASER UNIT.....	6-1
6.1.1 CAUTION DECAL LOCATIONS.....	6-1
6.1.2 LASER UNIT.....	6-2
7. TROUBLESHOOTING	7-1

OPTIONS

500-SHEET FINISHER (G302)

1. REPLACEMENT AND ADJUSTMENT.....	G302-1
1.1 EXTERIOR	G302-1
1.2 ENTRANCE UPPER GUIDE / PAPER EXIT UNIT	G302-4
1.3 ENTRANCE LOWER GUIDE	G302-5
1.4 PAPER EXIT UNIT GEAR / PADDLE ROLLER SOLENOID	G302-5
1.5 STAPLER UNIT	G302-6
1.6 JOGGER TRAY UNIT	G302-6
1.7 PAPER EXIT SENSOR FEELER	G302-7
1.8 MAIN MOTOR	G302-7
1.9 JOGGER MOTOR.....	G302-8
1.10 CONTROL BOARD	G302-8
1.11 SHIFT TRAY UNIT	G302-9
2. DETAILED DESCRIPTIONS	G302-10
2.1 OVERALL MACHINE INFORMATION	G302-10
2.1.1 COMPONENT LAYOUT	G302-10
Mechanical component layout	G302-10
Drive layout.....	G302-11
2.1.2 ELECTRICAL COMPONENT DESCRIPTIONS	G302-12
2.2 DETAILED SECTION DESCRIPTIONS	G302-14
2.2.1 SHIFT TRAY MECHANISM.....	G302-14
Stack height detection.....	G302-14
Shift tray up/down mechanism.....	G302-15
2.2.2 PAPER FEED	G302-16
Overview	G302-16
Straight feed out mode.....	G302-16
Shifting mode.....	G302-17
Staple mode.....	G302-19
2.2.3 JAM CONDITIONS	G302-20
2.2.4 ERROR DETECTION	G302-20
3. SPECIFICATIONS.....	G302-21

PAPER TRAY UNIT (A860): Common with Russian-P

1. OVERALL MACHINE INFORMATION	A860-1
1.1 SPECIFICATIONS.....	A860-1
1.2 MECHANICAL COMPONENT LAYOUT	A860-2
1.3 ELECTRICAL COMPONENT LAYOUT	A860-3
1.4 ELECTRICAL COMPONENT DESCRIPTION	A860-4
1.5 DRIVE LAYOUT	A860-5

2. DETAILED DESCRIPTIONS	A860-6
2.1 PAPER FEED AND SEPARATION MECHANISM	A860-6
2.2 PAPER LIFT MECHANISM	A860-7
2.3 PAPER END DETECTION	A860-9
2.4 PAPER HEIGHT DETECTION	A860-10
2.5 PAPER SIZE DETECTION.....	A860-12
2.6 SIDE AND END FENCES	A860-13
Side Fences.....	A860-13
End Fence	A860-13
3. REPLACEMENT AND ADJUSTMENT.....	A860-14
3.1 FEED ROLLER REPLACEMENT.....	A860-14
3.2 TRAY MAIN BOARD REPLACEMENT	A860-15
3.3 TRAY MOTOR REPLACEMENT	A860-15
3.4 RELAY CLUTCH REPLACEMENT	A860-16
3.5 UPPER PAPER FEED CLUTCH REPLACEMENT	A860-17
3.6 LOWER PAPER FEED CLUTCH REPLACEMENT	A860-18
3.7 LIFT MOTOR REPLACEMENT	A860-19
3.8 PAPER END SENSOR REPLACEMENT	A860-20
3.9 VERTICAL TRANSPORT SENSOR REPLACEMENT	A860-20
3.10 PAPER SIZE SWITCH REPLACEMENT	A860-21

LCT (A862): Common with Russian-P

1. OVERALL MACHINE INFORMATION	A862-1
1.1 SPECIFICATIONS.....	A862-1
1.2 MECHANICAL COMPONENT LAYOUT	A862-2
1.3 ELECTRICAL COMPONENT LAYOUT	A862-3
1.4 ELECTRICAL COMPONENT DESCRIPTIONS	A862-4
2. DETAILED SECTION DESCRIPTIONS	A862-5
2.1 PAPER FEED.....	A862-5
2.2 REVERSE ROLLER AND PICK-UP ROLLER RELEASE	A862-6
2.3 TRAY LIFT	A862-7
2.4 NEAR END/END DETECTION.....	A862-8
2.5 RIGHT TRAY SIDE FENCE	A862-9
2.6 LEFT TRAY REAR FENCE	A862-9
2.7 RIGHT TRAY PAPER END DETECTION	A862-10
3. REPLACEMENT AND ADJUSTMENT.....	A862-11
3.1 DETACHING THE TRAY FROM THE MAINFRAME.....	A862-11
3.2 REAR FENCE HP SENSOR	A862-11
3.3 CHANGING THE TRAY PAPER SIZE	A862-12
3.4 LEFT TRAY PAPER END SENSOR	A862-12
3.5 TRAY LIFT MOTOR	A862-13
3.6 TRAY MOTOR.....	A862-14

3.7 PAPER FEED CLUTCH AND RELAY CLUTCH.....	A862-15
3.8 PAPER FEED UNIT	A862-16
3.9 UPPER LIMIT RIGHT TRAY PAPER END AND RELAY SENSORS	A862-17
3.10 REAR FENCE MOTOR	A862-18
3.11 PICK-UP/PAPER FEED/REVERSE ROLLERS.....	A862-19

BY-PASS UNIT (A899): Common with Russian-P

1 OVERALL MACHINE INFORMATION	A899-1
1.1 SPECIFICATIONS.....	A899-1
1.2 MECHANICAL COMPONENT LAYOUT	A899-1
1.3 ELECTRICAL COMPONENT LAYOUT	A899-2
1.4 ELECTRICAL COMPONENT DESCRIPTION.....	A899-2
2 DETAILED DESCRIPTIONS	A899-3
2.1 BASIC OPERATION.....	A899-3
2.2 PAPER SIZE DETECTION.....	A899-4
3 REPLACEMENT AND ADJUSTMENT.....	A899-5
3.1 PAPER FEED ROLLER/FRICTION PAD/PAPER END SENSOR.....	A899-5
3.2 PAPER SIZE SENSOR BOARD.....	A899-6
3.3 PAPER FEED CLUTCH	A899-7

INTERCHANGE UNIT (G531): Common with Russian-P

1. OVERALL MACHINE INFORMATION	G531-1
1.1 SPECIFICATIONS.....	G531-1
1.2 MECHANICAL COMPONENT LAYOUT	G531-2
1.3 DRIVE LAYOUT	G531-3
2. DETAILED DESCRIPTION	G531-4
2.1 JUNCTION GATE MECHANISM.....	G531-4
To the Exit Tray or Bridge Unit (for the Upper Tray on top of the Bridge Unit or the Finisher)	G531-4
To the 1-bin Tray.....	G531-4
To the Duplex Unit	G531-4
3. REPLACEMENT AND ADJUSTMENT.....	G531-5
3.1 EXIT SENSOR REPLACEMENT.....	G531-5

DUPLEX UNIT (G582) : The contents of manual are the same as G529 manual.

1. OVERALL MACHINE INFORMATION	G529-1
1.1 SPECIFICATIONS.....	G529-1
1.2 MECHANICAL COMPONENT LAYOUT	G529-2
1.3 ELECTRICAL COMPONENT LAYOUT.....	G529-3
1.4 ELECTRICAL COMPONENT DESCRIPTION.....	G529-4
1.5 DRIVE LAYOUT	G529-5
2. DETAILED DESCRIPTIONS	G529-6
2.1 BASIC OPERATION.....	G529-6
Larger than A4 lengthwise/LT Lengthwise	G529-6
Up to A4 Lengthwise/LT lengthwise.....	G529-7
2.2 FEED IN AND EXIT MECHANISM	G529-8
When Paper is Fed Into Duplex Unit	G529-8
Inversion and Exit	G529-8
3. REPLACEMENT AND ADJUSTMENT.....	G529-9
3.1 COVER REMOVAL	G529-9
3.2 ENTRANCE SENSOR REPLACEMENT	G529-10
3.3 EXIT SENSOR REPLACEMENT.....	G529-11

BRIDGE UNIT (G583): The contents of manual are the same as A897 manual

1. OVERALL MACHINE INFORMATION	A897-1
1.1 SPECIFICATIONS.....	A897-1
1.2 MECHANICAL COMPONENT LAYOUT	A897-2
1.3 ELECTRICAL COMPONENT LAYOUT.....	A897-3
1.4 ELECTRICAL COMPONENT DESCRIPTION.....	A897-4
1.5 DRIVE LAYOUT	A897-5
2. DETAILED DESCRIPTION	A897-6
2.1 JUNCTION GATE MECHANISM.....	A897-6
3. REPLACEMENT AND ADJUSTMENT.....	A897-7
3.1 BRIDGE UNIT DRIVE MOTOR REPLACEMENT	A897-7
3.2 TRAY EXIT SENSOR REPLACEMENT	A897-8
3.3 RELAY SENSOR REPLACEMENT.....	A897-8

FINISHER (A681): Common with Russian-P

1. OVERALL MACHINE INFORMATION	A681-1
1.1 SPECIFICATIONS.....	A681-1
1.2 MECHANICAL COMPONENT LAYOUT	A681-2
1.3 ELECTRICAL COMPONENT LAYOUT.....	A681-3
1.4 ELECTRICAL COMPONENT DESCRIPTIONS	A681-4
1.5 DRIVE LAYOUT	A681-6
2. DETAILED DESCRIPTIONS	A681-7
2.1 JUNCTION GATE MECHANISM.....	A681-7
Staple Mode.....	A681-7
No staple Mode.....	A681-7
2.2 JOGGER UNIT PAPER POSITIONING MECHANISM.....	A681-8
2.3 EXIT GUIDE PLATE OPEN/CLOSE MECHANISM.....	A681-9
2.4 STAPLER	A681-10
2.5 FEED OUT MECHANISM	A681-11
2.6 SHIFT TRAY UP/DOWN MECHANISM	A681-12
2.7 SHIFT TRAY SIDE-TO-SIDE MECHANISM.....	A681-13
2.8 JAM CONDITIONS	A681-14
2.9 TIMING CHARTS	A681-15
2.9.1 NO STAPLE MODE (A4 SIDEWAYS 3 SHEETS/2SETS).....	A681-15
2.9.2 STAPLE MODE (A4 SIDEWAYS 2 SHEETS/2 SETS).....	A681-16
3. SERVICE TABLE	A681-17
3.1 DIP SWITCH TABLE	A681-17
3.2 TEST POINTS	A681-17
3.3 FUSES	A681-17
4. REPLACEMENT AND ADJUSTMENT.....	A681-18
4.1 COVER REMOVAL	A681-18
Front Door.....	A681-18
Front Cover.....	A681-18
Rear Cover	A681-18
Upper Cover	A681-18
Lower Left Cover	A681-19
Front Shift Tray Cover.....	A681-19
Rear Shift Tray Cover	A681-19
Shift Tray	A681-19
4.2 ENTRANCE SENSOR REPLACEMENT	A681-20
4.3 EXIT SENSOR REPLACEMENT.....	A681-21
4.4 STACK HEIGHT SENSOR REPLACEMENT	A681-22
4.5 POSITIONING ROLLER REPLACEMENT	A681-23
4.6 STAPLER REPLACEMENT	A681-24

MAILBOX (G518): Common with Russian-P

1. OVERALL MACHINE INFORMATION	G518-1
1.1 SPECIFICATIONS.....	G518-1
1.2 COMPONENT LAYOUT	G518-2
1.2.1 MECHANICAL COMPONENT LAYOUT	G518-2
1.2.2 DRIVE LAYOUT	G518-2
1.3 ELECTRICAL COMPONENT DESCRIPTIONS	G518-3
2. DETAILED DESCRIPTIONS	G518-5
2.1 BASIC OPERATION.....	G518-5
2.2 PAPER OVERFLOW DETECTION	G518-6
2.2.1 OVERVIEW	G518-6
2.2.2 DETECTION TIMING	G518-6
2.3 PAPER MISFEED DETECTION TIMING	G518-7
3. REPLACEMENT AND ADJUSTMENT.....	G518-9
3.1 EXTERIOR COVER REMOVAL.....	G518-9
3.2 TRAY OVERFLOW AND VERTICAL TRANSPORT SENSOR REPLACEMENT	G518-10
3.3 MAIN MOTOR REPLACEMENT	G518-11

1. OVERALL MACHINE INFORMATION

1.1 SPECIFICATIONS

1.1.1 GENERAL SPECIFICATIONS

Printing Speed	Maximum 32 pages per minute (A4/LT LEF) (25 pages duplex printing)
Printer Language	PCL 6 / PCL 5e PostScript 3
Resolution	Max. 600 dpi (PCL 6/PCL5e/PS3)
Resident Fonts	PCL 35 Intellifonts 10 True Type fonts 1 Bitmap font PS3 136 fonts (24 Type 2 fonts 112 Type 14 fonts)
Host Interface	Bi-directional IEEE1284 parallel x 1 (Standard) Ethernet (100 Base-TX/10 Base-T for TCP/IP IPX/SPX NetBEUI Apple Talk)
Printing Paper Size	Maximum A3/11 x 17 Minimum 1st paper Tray A5 SEF 2nd paper Tray A6 SEF By-pass A6/ 90 x 148 mm SEF (Refer to section 1.1.2 Supported Paper Size .)
Printing Paper Weight	1st paper tray 60 to 105 g/m ² (16 to 28 lb.) 2nd paper tray 60 to 157 g/m ² (16 to 42 lb.) By-pass Tray 60 to 200 g/m ² (16 to 110 Index)
Print Paper Capacity	1st and 2nd paper tray 500 sheets x 2 Optional paper tray unit 500 sheets x 2 Optional LCT 1000 sheets x 2 Optional by-pass tray 100 sheets
Output Paper Capacity	Standard output tray 500 sheets Optional 1000-finisher 1 000 sheets Optional 500-finisher 500 sheets Optional 4-bin mailbox 500 sheets total
First Print Speed	5 seconds or less (A4/LT LEF 1st tray)
Warm-up Time	Less than 45 seconds

Memory Standard 32 MB up to 160 MB with optional DIMM.
 Power Source 120 V 60 Hz More than 10 A (for North America)
 220 V - 240 V 50/60 Hz More than 6.0 A (for Europe)

Power Consumption

	120V	230V
Maximum (Full Option)	980W or less	980W or less
Printing	620W or less	620W or less
Energy Saver (Mode 1)	25 W or less	25 W or less

Noise Emission

	Mainframe Only	Full System
Sound Power Level		
Printing	65 dB or less	71 dB or less
Stand-by	40 dB or less	40 dB or less

NOTE: The above measurements were made in accordance with ISO 9296 at the operator position.

Dimensions (W x D x H) 550 x 548 x 516 mm

Weight Approximately 40 kg

1.1.2 SUPPORTED PAPER SIZES

No differences from base model (G038).
 Refer to the Field Service Manual for G308.

1.2 SOFTWARE ACCESSORIES

The printer drivers and utility software are provided on one CD-ROM. An auto-run installer allows you to select which components to install. The service tools are not provided on the CD-ROM.

1.2.1 PRINTER DRIVERS

Printer Language	Windows 95/98	Windows 2000	Windows NT4.0	Macintosh
PCL 6	Yes	Yes	Yes	No
PCL 5e	Yes	Yes	Yes	No
PS3	Yes	Yes	Yes	Yes

- NOTE:**
- 1) The printer drivers for Windows NT 4.0 are only for the Intel x86 platform. There is no Windows NT 4.0 printer driver for PowerPC Alpha or MIPS platforms.
 - 2) The PS3 drivers are all genuine AdobePS drivers. A PPD file for each operating system is provided with the driver.
 - 3) The PS3 drivers for Macintosh support Mac OS 7.1 or later versions.

1.2.2 UTILITY SOFTWARE

Software	Description
Agfa Font Manager (Win 95/98 2000 NT4)	A font management utility with screen fonts for the printer.
Printer Manager for Admin (Win 95/98 2000 NT4)	A printer management utility for network administrators. NIB setup utilities are also available.
Printer Manager for Client (Win95/98 2000 NT4)	A printer management utility for client users.
Port Navi (Win95/98 2000 NT4)	A peer to peer print utility over a TCP/IP network. This provides parallel printing and recovery printing function.
Multi-Direct Print (Win95/98 2000 NT4)	A utility for peer-to-peer printing over a NetBEUI or TCP/IP network.
Acrobat Reader	Document reader for PDF format

1.2.3 SERVICE TOOLS

Software	Description
NBTFTP	NIB firmware update utility for use on a NetBEUI network. This utility is not on the Driver and Utilities CD-ROM it is issued separately as a service tool

1.3 MACHINE CONFIGURATION

1.3.1 SYSTEM COMPONENTS

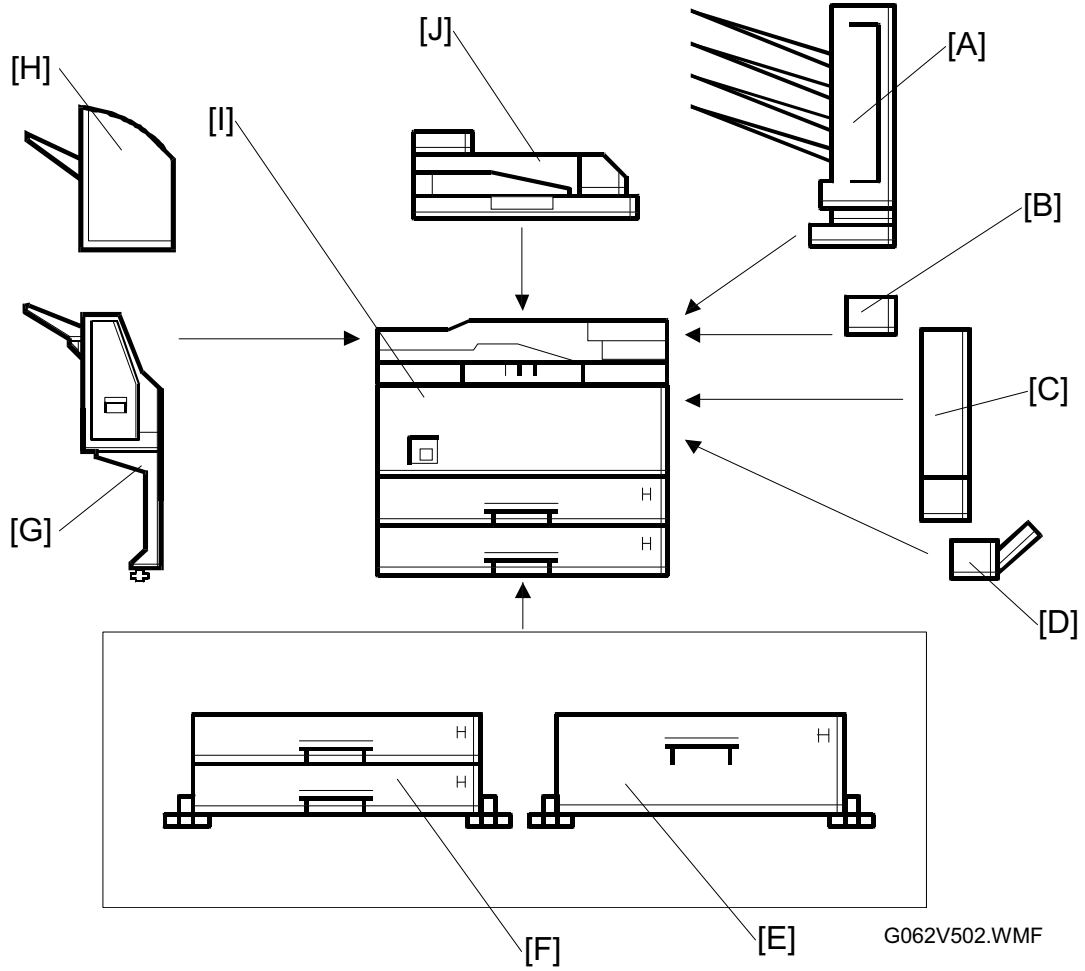

Item	Machine Code	No.	Installable by	Remarks
Main Unit	G062	I	User	
Option				
Paper Tray Unit - 2 trays	A860	F	User (Note 1)	Common with Stinger-C/Russian-C/P with modified motor.
LCT	A862	E	User (Note 1)	Common with Russian-C/P with modified tray motor.
By-pass Tray	A899	D	User	Common with Russian-C/P
Interchange Unit	G531	B	User	Common with Russian-P
Duplex Unit	G582	C	User (Note 2 3)	New model
4-bin Mailbox	G518	A	User (Note 2)	Common with Russian-P with modified motor and driver board.
Bridge Unit	G583	J	User	New model
500-sheet Finisher	G302	H	User	New model
1000-sheet Finisher	A681	G	Service (Note 4)	Common with Russian-C/P/NAD
Internal Option				
HDD	G690		User	Common with Stinger-C/Russian-C/P
Memory 32MB	G578		User	
Memory 64MB	G579		User	
Memory 128MB	G580		User	
Others				
Maintenance Kit	G719			

- NOTE:** 1) Only one of these options can be installed on the machine.
 2) Requires the installation of the Interchange unit.
 3) Requires the installation of the memory option.
 4) The Bridge unit must be installed together with the 1000 sheet Finisher.
 Either the LCT or Paper Tray Unit (2 trays) must also be installed.

1.4 ELECTRICAL COMPONENT DESCRIPTIONS

Refer to the electrical component layout on the reverse side of the point-to-point diagram for component location.

A polygonal mirror motor fan (M7) was added.

Symbol	Name	Function
Motors		
M1	Polygonal Mirror	Turns the polygonal mirror.
M2	Main Motor	Drives the main unit components.
M3	Exhaust Fan	Removes heat from around the fusing unit.
M4	Upper Paper Lift	Raises the bottom plate in the 1st paper tray.
M5	Lower Paper Lift	Raises the bottom plate in the 2nd paper tray.
M6	Toner Supply	Rotates the toner bottle to supply toner to the development unit.
M7	Polygonal Mirror Motor Fan	Removes heat from around the optical unit
Magnetic Clutches		
MC1	Upper Paper Feed	Starts paper feed from the 1st paper tray.
MC2	Lower Paper Feed	Starts paper feed from the 2nd paper tray.
MC3	Upper Paper Transport	Drives the upper transport rollers.
MC4	Lower Paper Transport	Drives the lower transport rollers.
MC5	Registration	Drives the registration rollers.
Switches		
SW1	Main Switch	Provides power to the machine. If this is off there is no power supplied to the machine.
SW2	Right Upper Cover	Detects whether right upper cover is open or not.
SW3	Right Cover	Cuts the +5VLD and +24V dc power line and detects whether the right cover is open or not.
SW4	Right Lower Cover	Detects whether right lower cover is open or not.
SW5	Upper Paper Size	Determines what size of paper is in the upper paper tray.
SW6	Lower Paper Size	Determines what size of paper is in the Lower paper tray.
SW7	Special Paper	Determines the special paper is in the lower paper tray.
SW8	New PCU Detect	Detects when a new PCU is installed.
SW9	Front Cover Safety	Cuts the +5VLD and +24V dc power line and detects whether the front cover is open or not.
Sensors		
S1	Toner Density (TD)	Detects the amount of toner inside the development unit.
S2	1st Paper End	Informs the CPU when the 1st paper tray runs out of paper.
S3	1st Paper End	Informs the CPU when the 2nd paper tray runs out of paper.
S4	Image Density (ID)	Detects the density of various patterns and the reflectivity of the drum for process control.
S5	Paper Overflow	Detects paper overflow condition.
S6	Paper Exit	Detects misfeeds.
S7	Upper Relay	Detects misfeeds.

Symbol	Name	Function
S8	Lower Relay	Detects misfeeds.
S9	Registration	Detects misfeeds and controls registration clutch off-on timing.
S10	1st Paper Lift	Detects when the paper in the 1st paper tray is at the feed height.
S11	2nd Paper Lift	Detects when the paper in the 2nd paper tray is at the feed height.
S12	1st Paper Height - 1	Detects the amount of paper in the 1st paper tray.
S13	1st Paper Height - 2	Detects the amount of paper in the 1st paper tray.
S14	2nd Paper Height - 1	Detects the amount of paper in the 2nd paper tray.
S150	2nd Paper Height - 2	Detects the amount of paper in the 2nd paper tray.
PCBs		
PCB1	Engine Board	Controls all printer engine functions.
PCB2	Printer Controller Board	Controls the printer functions
PCB3	Network Interface Board	Network interface board
PCB4	PSU (Power Supply Unit)	Provides dc power to the system and ac power to the fusing lamp and heaters.
PCB5	LDD (Laser Diode Driver)	Controls the laser diode.
PCB6	Operation Panel	Controls the operation panel.
PCB7	High Voltage Supply	Supplies high voltage to the drum charge roller development roller and transfer roller.
PCB8	Memory (Option)	Expands memory capacity.
Lamps		
L1	Fusing Lamp	Heats the hot roller.
L2	Quenching Lamp	Neutralizes any charge remaining on the drum surface after cleaning.
Others		
TF1	Fusing Thermofuse	Opens the fusing lamp circuit if the fusing unit overheats.
TH1	Fusing Thermistor	Detects the temperature of the hot roller.
LSD 1	Laser Synchronization Detector	Detects the laser beam at the start of the main scan.

1.5 BOARD STRUCTURE

1.5.1 OVERVIEW

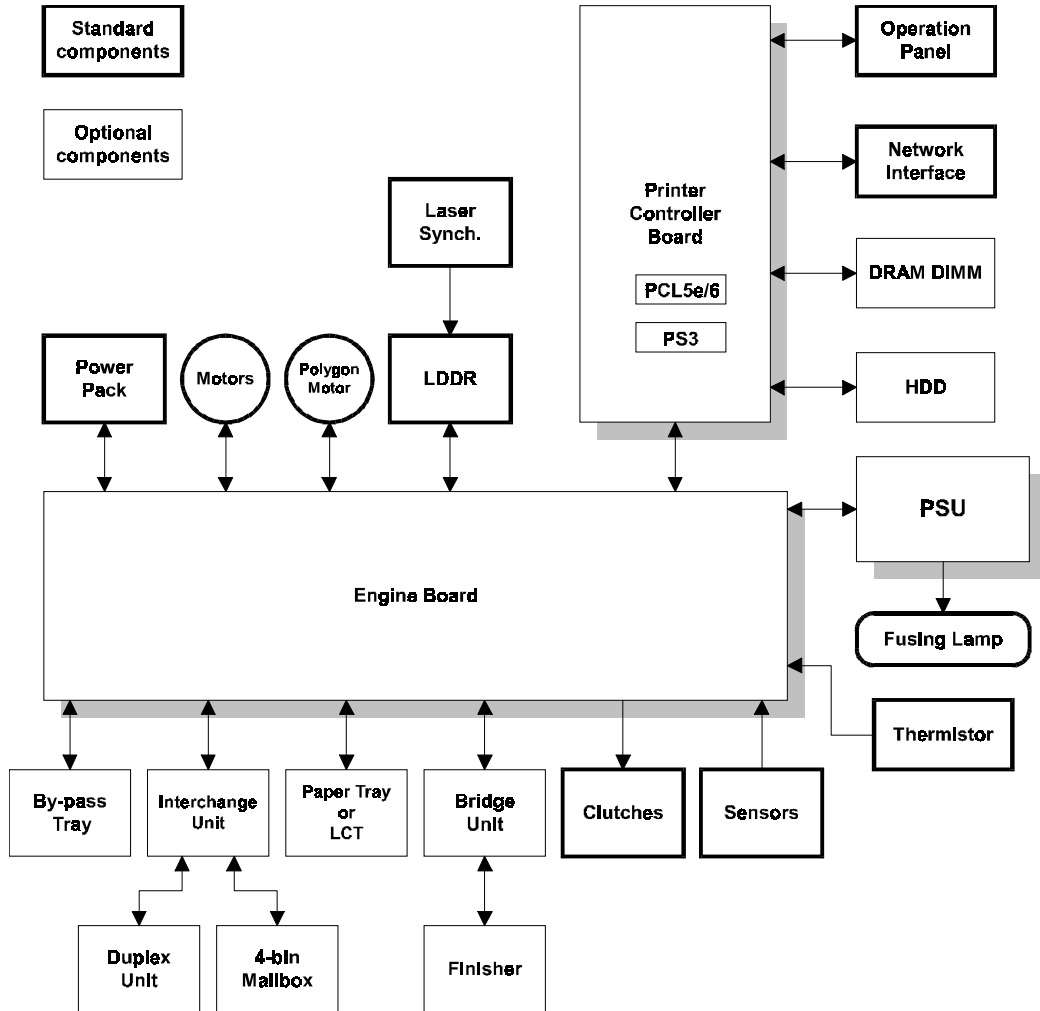

G062V501.WMF

The PS module is contained in the Printer Controller Board.

2. DETAILED SECTION DESCRIPTIONS

2.1 DIFFERENT POINTS FROM BASE MODEL (G038)

2.1.1 OVERVIEW

The following points are different from the base model (G038)

1. Printing Speed

	G062	Base Model (G038)
Printing Speed	32 ppm (25 ppm duplex printing)	27 ppm (22 ppm duplex printing)

Detailed Descriptions

To obtain the above higher printing speed the following sections were changed from the base model G038.

- 1) Paper feed
- 2) Laser exposure
- 3) Development (Quenching)
- 4) Engine controller
- 5) Printer controller

2. Controller features

The following features were added.

- 1) Locked print
- 2) Sequential stack

2.1.2 PAPER FEED SECTION

The followings differ from the base model (G038) in the paper feed section to get higher printing speed.

1. Registration roller
The diameter of the gears were changed.
2. Registration pressure roller and pressure springs
The diameter of the roller and pressure force of springs were changed.
3. Relay rollers
Diameter of upper and lower relay roller is changed.
4. The number of flywheels was changed from 3 to 2 in order to stabilize the rotation of the main motor.

2.1.3 LASER EXPOSURE SECTION

The following optical unit items differ from the base model(G038).

1. Polygonal Mirror Motor
An increase in the speed of the polygonal mirror motor enables an increase in the printing speed.

	G062	Base Model (G038)
Mirror motor revolution speed	38 000 rpm	31 000 rpm

2. Polygonal Mirror Motor Fan
A polygonal mirror motor fan was added to remove heat from around the Optical unit.

2.1.4 DEVELOPMENT SECTION

The preheating lamp was changed to increase the amount of light.

2.1.5 ENGINE CONTROLLER BOARD

1. The fusing temperature in energy saver mode was changed.

Energy saver mode	G062	Base Model (G038)
Level 1	140 °C	60 °C
Level 2	Off	Off

2. The hardware and firmware were changed to increase the printing speed.

2.1.6 CONTROLLER BOARD

The following items differ from the base model

1. A PS DIMM was included in the printer controller board.
2. CPU and standard memory size were changed for higher performance.

	G062	Base Model (G038)
CPU	RM5261 250MHz	Vr.4310 167MHz
Standard Memory	32 MB	16 MB

3. New controller features

Locked print

This function protects users confidentiality for printouts using a shared printer when anyone wishes to print confidential documents. With this function documents will not print out unless the user enters a valid password which was entered in the Printer Driver when sending the print ob(s) at the printer controller panel. This function is only applicable when the optional HDD is attached.

	Capacity
Max. Storing pages	2000 pages
Max. Job storing	30 obs
Max. Overflow job record	20 obs
Max. Storing capacity (HDD)	2GBMB

These figures are for both the sample and locked print functions.

Sequential stack

This function with optional mailbox enables the user to continue printing by automatically changing output trays when the current output tray becomes full. To enable this function select Sequential Stack mode from the operation panel.

The output tray will automatically be chosen as follows.

(Case 1 Finisher is attached)

Finisher Tray - Mailbox Tray 1 - Mailbox Tray 2 - Mailbox Tray 3 -
Mailbox Tray 4
Standard Tray (on the bridge unit) will not be used as output tray.

(Case 2 Finisher is not attached)

Standard Tray - Mailbox Tray 1 - Mailbox Tray 2 - Mailbox Tray 3 -
Mailbox Tray 4

Other conditions and remarks are as follows.

- 1) The tray will automatically change after the full stack detection sensor is activated for each tray.
- 2) When Mailbox Tray 4 is full the Remove Paper All Tray message appears on the LCD.
- 3) When all of the paper is removed from all of the trays (cancelled full stack detection) printing will restart from the Finisher Tray (Case 1) or the Standard Tray (Case 2).
- 4) When Collation is selected SHIFT/SORT will be enabled on the Finisher Tray but rotate collation will be disabled for the Mailbox Trays. (Case 1)
- 5) When Collation is selected rotate collation will be enabled. (Case 2)
- 6) When Staple is selected it will be enabled on the Finisher Tray.
- 7) When Sequential Stack is selected during continuous multiple print jobs the tray will not be change between 2 different jobs. It will continue to output paper to the current tray until the tray becomes full. Then it will switch to another tray.
- 8) If any tray is out of order that particular tray will be skipped and if there are no trays to change to the machine will indicate Remove Paper All Tray as in step 2.

3. INSTALLATION

3.1 INSTALLING THE MACHINE

Refer to the Setup Guide for information about the installation environment and instructions on how to install and set up this machine. Installation procedures for the following items are described.

- Paper Tray (2 trays)
- LCT
- By-pass Tray Unit
- Interchange Unit
- Duplex Unit
- 4-bin Mailbox Unit
- Bridge Unit
- 500-Sheet Finisher
- Memory (SDRAM DIMM)
- HDD Unit

If the customer has a service contract with a meter click system and counter indication is required set up the counter with an SP mode as follows

1. Enter the Service mode.
2. Set 1 at the bit1 of C. BitSw 3 set in Service Menu1.
3. Exit Service mode
4. Confirm the counter is indicated on operation panel by pressing [Menu] and [Enter] keys.

3.2 INSTALLING OPTIONAL UNITS

⚠ CAUTION

Before installing this option, do the following:

- 1. Print out all data in the printer buffer.**
- 2. Turn off the switch and disconnect the power cord.**

3.2.1 1,000-SHEET FINISHER

NOTE: The following options must be installed before installing this finisher

- Bridge Unit (G583)
- Paper Tray Unit (G532) or LCT (G539)

Installation Procedure

1. Unpack the finisher and remove the tapes.

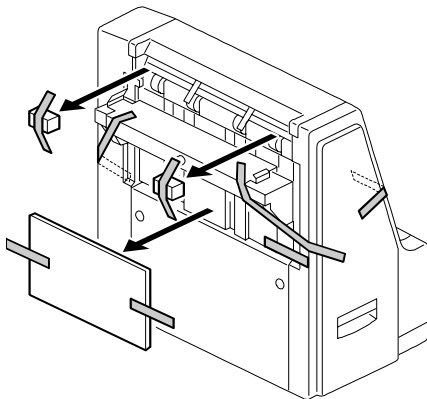

A6811503.WMF

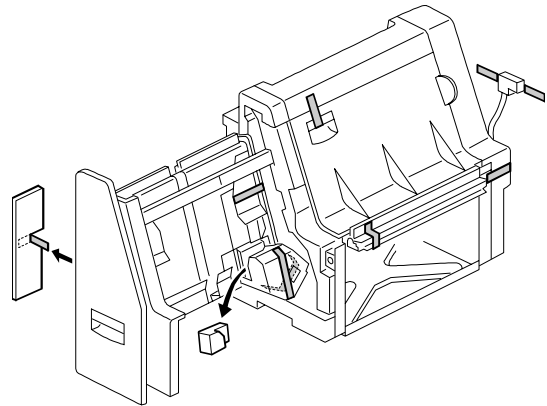

A6811504.WMF

2. Install screw [A] loosely.
3. Hang the front stand [B] on the screw that was installed in step 2.
4. Secure the front stand (3 screws including screw [A]).
5. Install the rear stand [C] (2 screws).

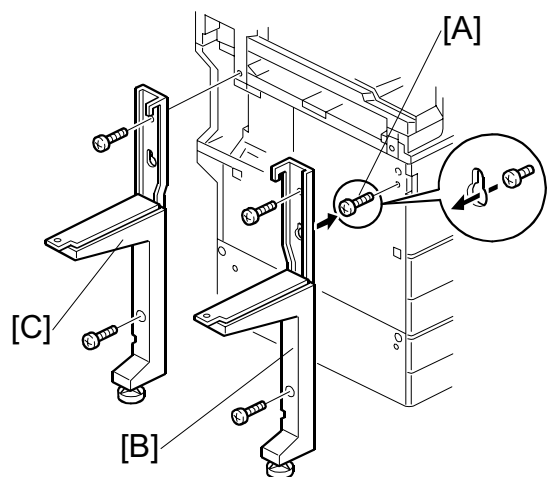

A681101.WMF

6. Pull out the stapler unit [D].
7. Draw out the locking lever [E] (1 screw).
8. Align the finisher on the stands and lock it in place by pushing the locking lever.
9. Secure the locking lever (1 screw) and push the stapler unit into the finisher.

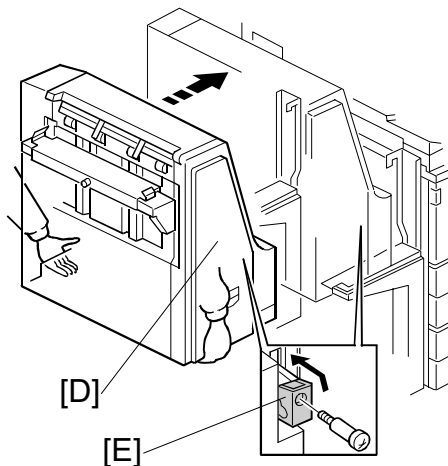

A6811502.WMF

10. Secure the finisher (1 screw from step 2).
11. Adjust the securing knobs [F] under the front and rear stand until the finisher is perpendicular to the floor [G].
12. Install the shift tray [G] (1 snap ring).
NOTE: Make sure that the three pegs [H] fit into the slots [I] properly.
13. Connect the finisher cable [J] to the optional bridge unit.
14. Turn on the main switch and check the finisher operation.

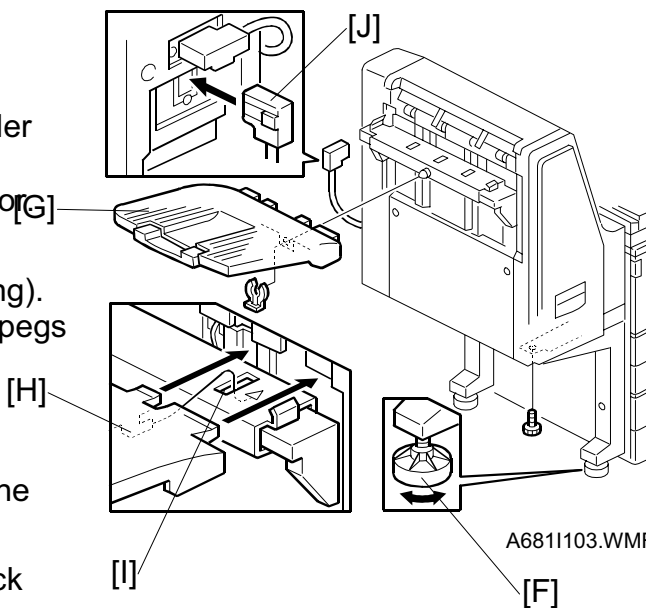

A6811103.WMF

End of procedure

Installation

4. SERVICE TABLES

4.1 PRINTER CONTROLLER SERVICE MODE

The following Bit Switches were added to the base model G038.

	Title	Description	Function / Note
C	BitSw 3 Set	Bit 1 Counter indication 0 Disable (default) 1 Enable	The customer can view the Charge Counter on the LCD panel using the Menu function.
		Bit 2 Job uniting 0 Disable (default) 1 Enable	Uniting obs if PC sends the next ob before printer completes the current ob. (see note)
		Bit 3 HP GL/2 Emulation 0 Normal (default) 1 Enhancing thin lines	If thin lines can not be reproduced with CAD application set this bit 1 .
		Bit 4 DAZEL compatibility 0 Enable (default) 1 Disable	If malfunction occurs on the printer because of ob command disabling this switch.
		Bit 5 Not used	
		Bit 6 Not used	
		Bit 7 Not used	
		Bit 8 Border pattern printing 0 Disable (default) 1 Enable	The border pattern is printed on the Configuration sheet for leading edge/side-to-side registration ad ustment.

Service Tables

NOTE: When enabling this function the Jog log does not show the actual ob and ob canceling is applied to whole combined obs.

4.2 PRINTER ENGINE SERVICE MODE

Only the title of the following service menu differs from the base model G038.



Menu Level			Function	Settings
Level 1	Level 2	Description		
3: Notify PM Alarm		Maintenance replacement warning and	Select enabling / disabling PM alert and printing stop after 5K printing from the alert.	0.Alert only 1.Stop printing 2.No message

4.3 CONTROLLER FIRMWARE UPDATE

4.3.1 FIRMWARE DOWNLOAD

The PS module is contained in the controller. The following two types of firmware can be individually downloaded through the IC card connector on the controller.

- Controller firmware including PS module
- NIB firmware

The procedure is the same as base model G038.

29 September 2000

5. PREVENTIVE MAINTENANCE

No differences from the base model G038.
Refer to the Field Service Manual for G038.

Preventive
Maintenance

6. REPLACEMENT AND ADJUSTMENT

6.1 LASER UNIT

WARNING

Turn off the main power switch and unplug the machine before attempting any of the procedures in this section. Laser beams can seriously damage your eyes.

6.1.1 CAUTION DECAL LOCATIONS

The CAUTION decal is located in the laser section as shown below.



G062R500.WMF

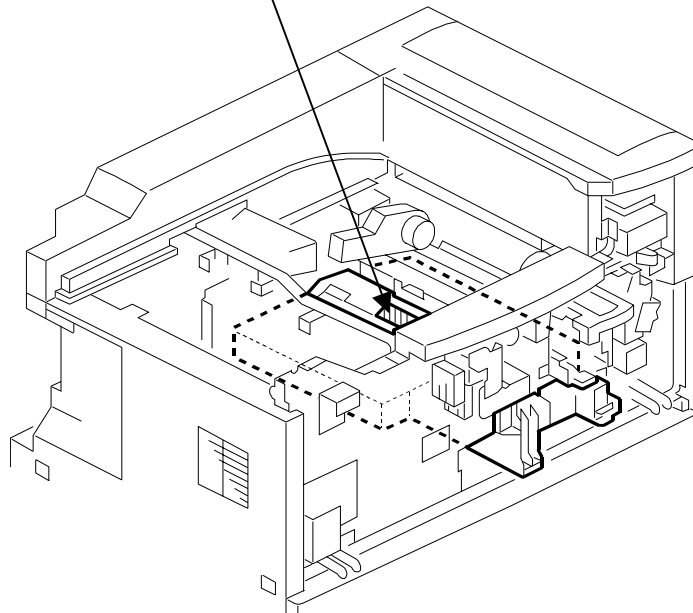

G062R501.WMF

Replacement
Adjustment

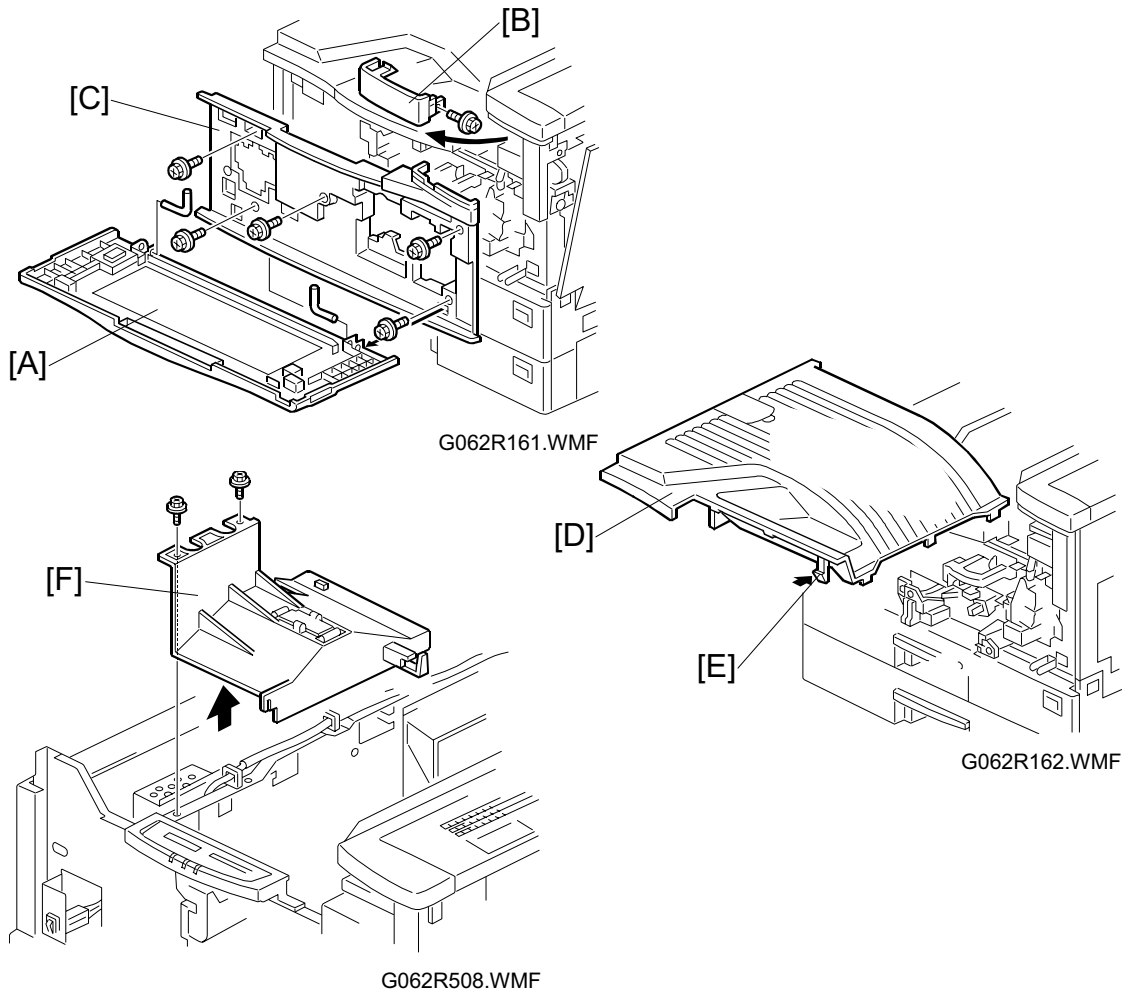
6.1.2 LASER UNIT**⚠ WARNING**

Turn off the main switch and unplug the machine before attempting any of the procedures in this section. Laser beams can seriously damage your eyes.

1. Remove the optional finisher and/or bridge unit if these units have been installed.
2. Remove the front cover [A] (2 pins).
3. Remove the right front cover [B] (1 screw).
4. Swing up the toner bottle lever. Then remove the inner cover [C] (5 screws).
5. Remove the paper exit tray [D] (1 hook [E]).
6. Remove the polygon mirror motor fan together with holder [F]. (1 connector 2 screws)

7. TROUBLESHOOTING

No differences from the base model G038.
Refer to the Field Service Manual for G038.

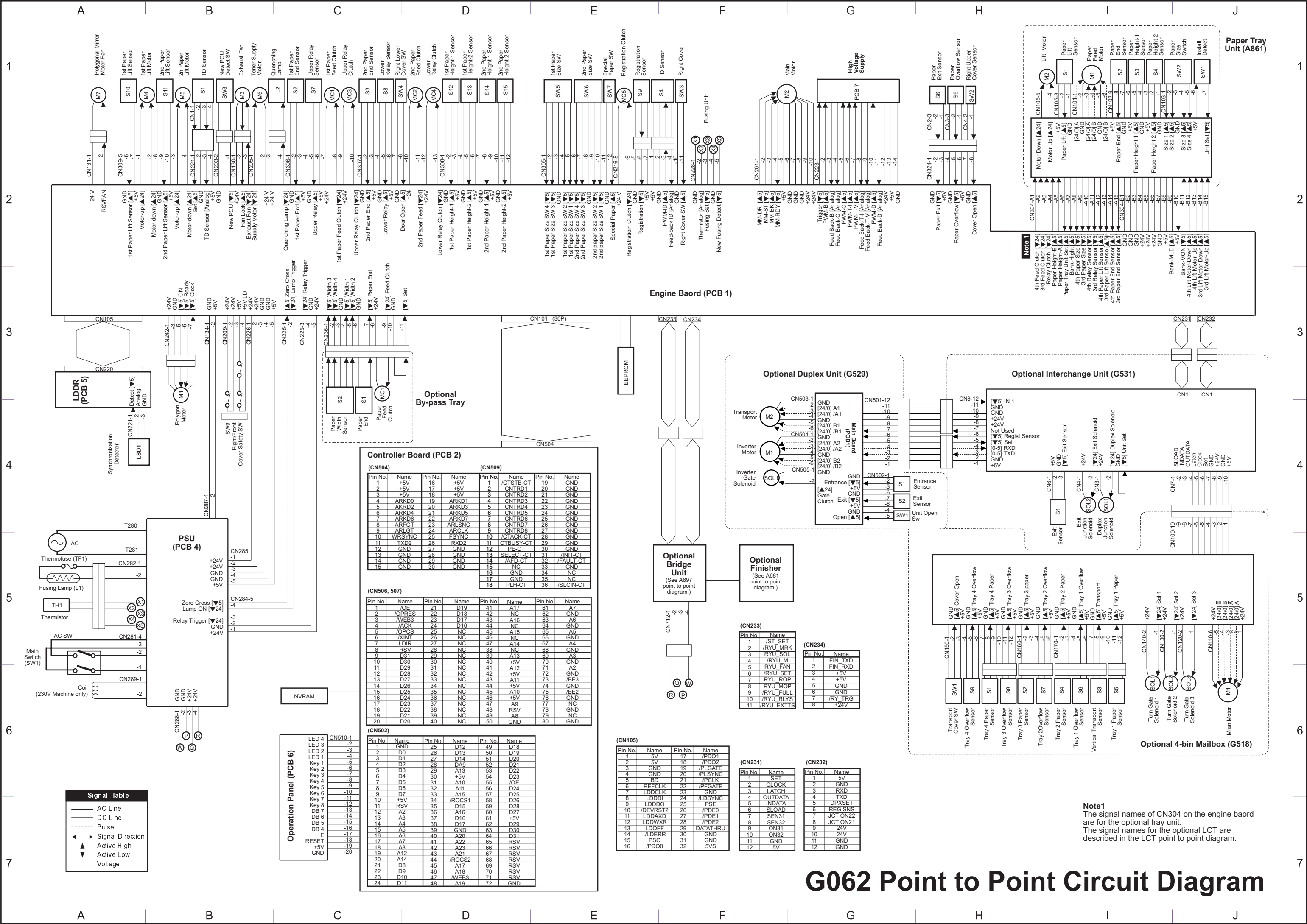

Signal Table

- AC Line
- DC Line
- Pulse
- Signal Direction
- Active High
- Active Low
- Voltage

Operation Panel (PCB 6)

LED 4	CN510-1
LED 3	CN510-2
LED 2	CN510-3
LED 1	CN510-4
Key 1	CN510-5
Key 2	CN510-6
Key 3	CN510-7
Key 4	CN510-8
Key 5	CN510-9
Key 6	CN510-10
Key 7	CN510-11
Key 8	CN510-12
DB 7	CN510-13
DB 6	CN510-14
DB 5	CN510-15
DB 4	CN510-16
E	CN510-17
RESET	CN510-18
+5V	CN510-19
GND	CN510-20

Controller Board (PCB 2)

(CN504)				(CN509)			
Pin No.	Name	Pin No.	Name	Pin No.	Name	Pin No.	Name
1	+5V	16	+5V	1	/CTSTB-CT	19	GND
2	+5V	17	+5V	2	CNTRD1	20	GND
3	+5V	18	+5V	3	CNTRD2	21	GND
4	ARKD0	19	ARKD1	4	CNTRD3	22	GND
5	ARKD2	20	ARKD3	5	CNTRD4	23	GND
6	ARKD4	21	ARKD5	6	CNTRD5	24	GND
7	ARKD6	22	ARKD7	7	CNTRD6	25	GND
8	ARFGT	23	ARLNC	8	CNTRD7	26	GND
9	ARLGT	24	ARCLK	9	CNTRD8	27	GND
10	WRSYNC	25	FSYNC	10	/CTACK-CT	28	GND
11	TXDZ	26	RXDZ	11	CTBUSY-CT	29	GND
12	GND	27	GND	12	/PF-CT	30	GND
13	GND	28	GND	13	SELECT-CT	31	/INIT-CT
14	GND	29	GND	14	/ADF-CT	32	/FAULT-CT
15	GND	30	GND	15	NC	33	GND
				16	GND	34	NC
				17	GND	35	NC
				18	PLH-CT	36	/SLCIN-CT

(CN506, 507)

Pin No.	Name	Pin No.	Name	Pin No.	Name	Pin No.	Name
1	IOE	21	D19	41	A17	61	A7
2	/OPRES	22	D18	42	NC	62	GND
3	/WEB3	23	D17	43	A16	63	A6
4	/ACK	24	D16	44	NC	64	GND
5	/OPCS	25	NC	45	A15	65	A5
6	/XINT	26	NC	46	NC	66	GND
7	LDIR	27	NC	47	A14	67	A4
8	RSV	28	NC	48	NC	68	GND
9	D31	29	NC	49	A13	69	A3
10	D30	30	NC	40	+5V	70	GND
11	D29	31	NC	41	A12	71	A2
12	D28	32	NC	42	+5V	72	GND
13	D27	33	NC	43	A11	73	/BE3
14	D26	34	NC	44	+5V	74	GND
15	D25	35	NC	45	A10	75	/BE2
16	D24	36	NC	46	+5V	76	GND
17	D23	37	NC	47	A9	77	NC
18	D22	38	NC	48	RSV	78	GND
19	D21	39	NC	49	A8	79	NC
20	D20	40	NC	50	GND	80	GND

(CN502)

Pin No.	Name	Pin No.	Name	Pin No.	Name
1	GND	25	D12	49	D18
2	D0	26	D13	50	D19
3	D1	27	D14	51	D20
4	D2	28	DA9	52	D21
5	D3	29	A13	53	D22
6	D4	30	+5V	54	D23
7	D5	31	A10	55	/OE
8	D6	32	A11	56	D24
9	D7	33	A15	57	D25
10	+5V	34	/ROCS1	58	D26
11	RSV	35	D15	59	D28
12	A2	36	A16	60	D27
13	A3	37	D16	61	+5V
14	A4	38	D17	62	D29
15	A5	39	GND	63	D30
16	A6	40	A20	64	D31
17	A7	41	A22	65	RSV
18	A8	42	A23	66	RSV
19	A12	43	A21	67	RSV
20	A14	44	/ROCS2	68	RSV
21	D8	45	A17	69	RSV
22	D9	46	A18	70	RSV
23	D10	47	/WEB3	71	RSV
24	D11	48	A19	72	GND

(CN105)

Pin No.	Name	Pin No.	Name
1	5V	17	/PDO1
2	5V	18	/PDO2
3	GND	19	/PLGATE
4	GND	20	/PLSYNC
5	BD	21	/PCLK
6	REFCLK	22	/PFGATE
7	LDDCLK	23	GND
8	LDDDI	24	/LDSYNC
9	LDDDO	25	PSE
10	/DEVRS12	26	/PDE0
11	LDDAXD	27	/PDE1
12	LDDWXR	28	PDE2
13	LDOFF	29	DATATHRU
14	/LDERR	30	GND
15	PSO	31	GND
16	/PDO0	32	5VS

(CN233)

Pin No.	Name
1	/ST SET
2	/RYU MRK
3	/RYU SOL
4	/RYU M
5	RYU FAN
6	/RYU SET
7	RYU ROP
8	RYU MOP
9	/RYU FULL
10	/RYU RLYS
11	/RYU EXITS
12	+24V

(CN234)

Pin No.	Name
1	SET
2	CLOCK
3	LATCH
4	OUTDATA
5	DPXSET
6	SLOAD
7	SEN31
8	SEN32
9	ON31
10	ON32
11	GND
12	5V

(CN231)

Pin No.	Name
1	SET
2	CLOCK
3	LATCH
4	OUTDATA
5	INDATA
6	SLOAD
7	JCT ON22
8	SEN32
9	ON31
10	ON32
11	GND
12	5V

(CN232)

Pin No.	Name
1	5V
2	GND
3	RXD
4	TXD
5	DPXSET
6	REG SNS
7	JCT ON22
8	JCT ON21
9	24V
10	24V
11	GND
12	GND

Note 1
The signal names of CN304 on the engine board are for the optional tray unit.
The signal names for the optional LCT are described in the LCT point to point diagram.

G062 Point to Point Circuit Diagram

PRINTER (G062) ELECTRICAL COMPONENT LAYOUT

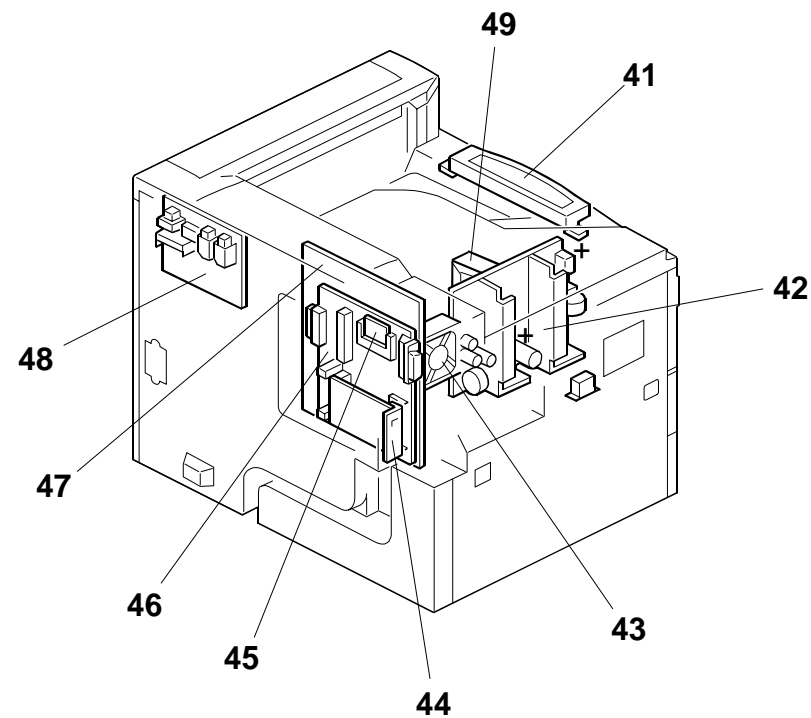
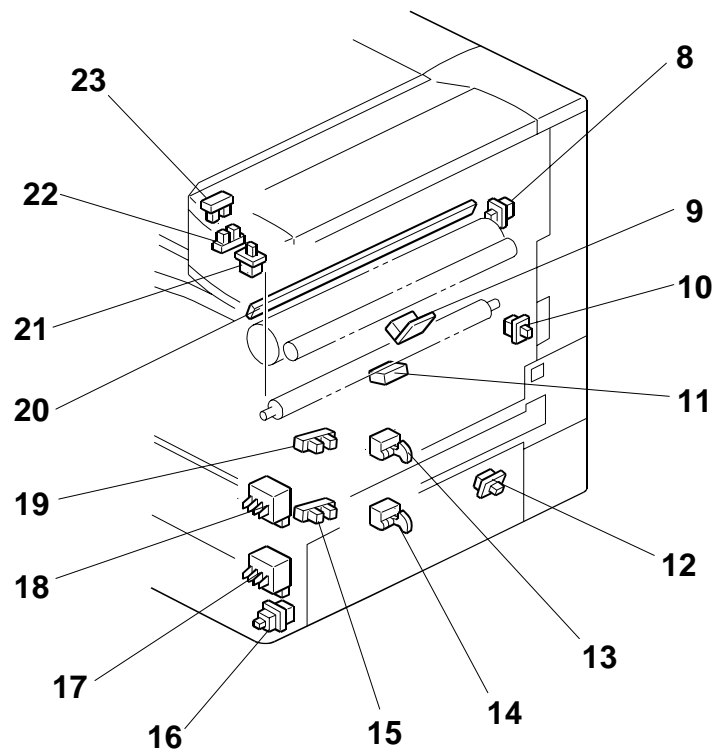
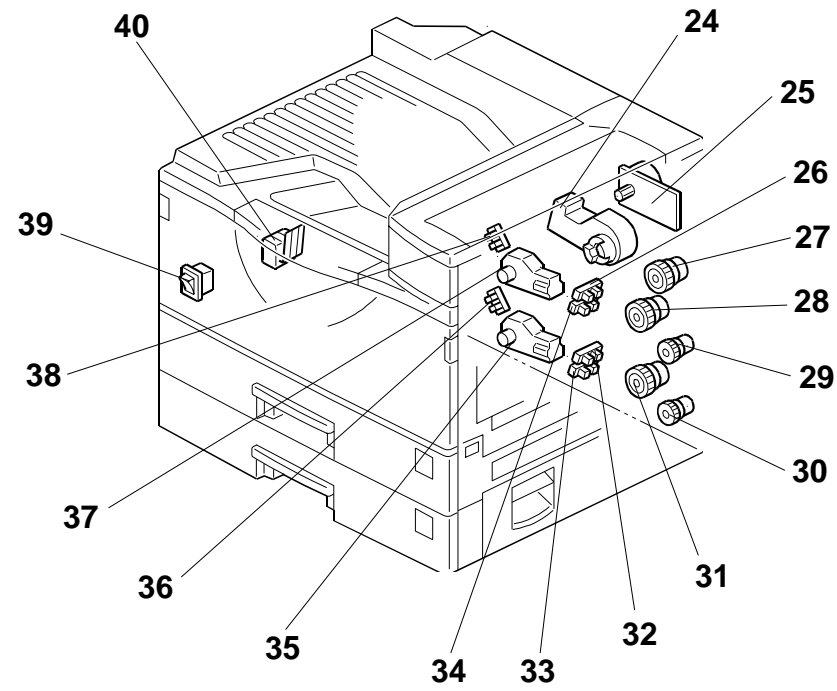
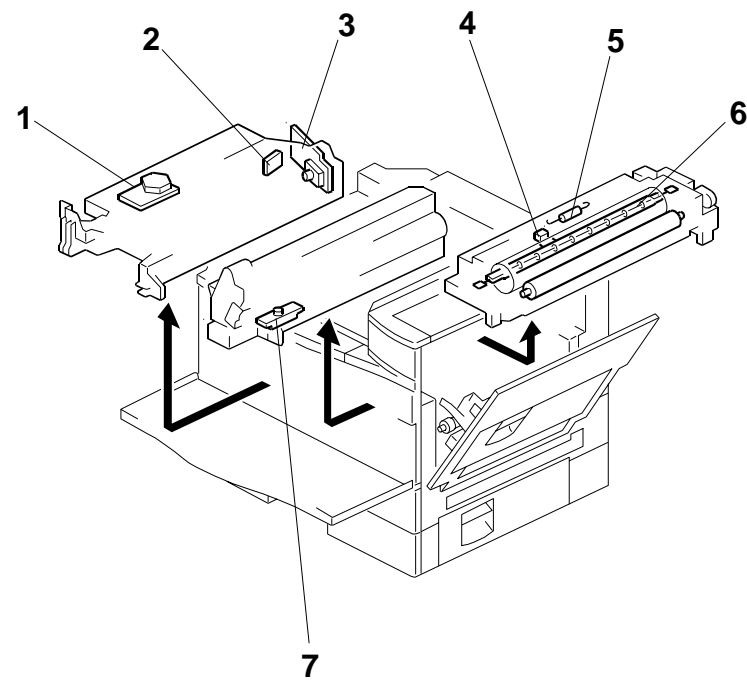

Symbol	Name	Index No.	P to P
Motors			
M1	Polygonal Mirror	1	B3
M2	Main Motor	25	G2
M3	Exhaust Fan	43	B1
M4	1st Paper Lift	37	B1
M5	2nd Paper Lift	35	B1
M6	Toner Supply	24	B1
M7	Polygonal Mirror Motor Fan	49	A1
Magnetic Clutches			
MC1	1st Paper Feed	28	C1
MC2	2nd Paper Feed	31	D1
MC3	Upper Relay	29	C1
MC4	Lower Relay	30	D1
MC5	Registration	27	E1
Switches			
SW1	Main Switch	39	A5
SW2	Right Upper Cover	21	H1
SW3	Right Cover	10	F1
SW4	Right Lower Cover	12	D1
SW5	1st Paper Size	18	E1
SW6	2nd Paper Size	17	E1
SW7	Special Paper	16	E1
SW8	New PCU Detect	8	B1
SW9	Front Cover Safety	40	B3
Sensors			
S1	Toner Density (TD)	7	B1
S2	1st Paper End	19	C1
S3	2nd Paper End	15	C1
S4	Image Density (ID)	9	S4
S5	Paper Overflow	23	H1
S6	Paper Exit	22	H1
S7	Upper Relay	13	C1
S8	Lower Relay	14	C1
S9	Registration	11	E1
S10	1st Paper Lift	38	A1
S11	2nd Paper Lift	36	B1
S12	1st Paper Height - 1	26	D1
S13	1st Paper Height - 2	34	D1
S14	2nd Paper Height - 1	32	D1
S15	2nd Paper Height - 2	33	D1
PCBs			
PCB1	Engine Board	47	F2
PCB2	Printer Controller Board	46	D4
PCB3	Network Interface Board	44	---
PCB4	PSU (Power Supply Unit)	42	B5
PCB5	LDD (Laser Diode Driver)	3	A3
PCB6	Operation Panel	41	C7
PCB7	High Voltage Supply	48	G1
PCB8	Memory (Option)	45	---
Lamps			
L1	Fusing Lamp	6	A5
L2	Quenching Lamp	20	C1
Others			
TF1	Fusing Thermofuse	5	A5
TH1	Fusing Thermistor	4	A5
LSD 1	Laser Synchronization Detector	2	A4